



CALIFORNIA NON-FUEL MINERAL PRODUCTION-2001

Based on the U.S. Geological Survey's (USGS) preliminary data for 2001, California ranked first among the states in non-fuel mineral production, accounting for approximately 8.4% of the United States total. Mineral production for California amounted to \$3.27 billion, a 1% decrease from 2000. Production of at least 32 types of industrial minerals accounted for 96% of the total value; gold and silver accounted for 4%. California was the only producer of boron, rare earth ore, and asbestos, and continued to lead the nation in the production of sand and gravel, diatomite, and natural sodium sulfate. California ranked fourth in the nation for gold production behind Nevada, Utah and Alaska. California dropped to second place for portland cement behind Texas. Other minerals produced in California include bentonite clay (including hectorite), common clay, crushed stone, dimension stone, feldspar, fire clay, fuller's earth, gemstones, gypsum, iron ore, kaolin clay, lime, magnesium compounds, perlite, pumice, pumicite, pyrophyllite, salt, silver, soda ash, sodium bicarbonate, talc, and zeolites.

California has about 1,000 active mines producing non-fuel minerals. There are approximately 9,300 employees at the mines and processing plants.

INDUSTRIAL MINERALS

Construction sand and gravel was California's leading industrial mineral with a value of \$953 million for 2001, a 1% increase from 2000. Sand and gravel production remained the same as in 2000. Portland cement had the second largest industrial mineral production with 11.2 million tons valued at \$768 million. Boron valued at \$557 million, ranked third and crushed stone ranked fourth with a value of \$380 million.

METALLIC MINERALS

Gold production continued to decline during 2001 producing 449,200 troy ounces, valued at \$122.3 million. This is a 19% decrease in production and 21% decrease in value from 2000. In the next 2-3 years, California's gold production is expected to drop by 70%.

Silver production makes up less than 1% of California's total metal production. Silver produced in California is a byproduct of gold production. Iron was produced (it's used in the production of portland cement) and is included in the industrial mineral category.



Molycorp Inc.'s world-class rare earths Mountain Pass Mine in San Bernardino County. The ore mined from the quarry is bastnasite, a cesium lanthanum carbonate, which contains 15 different rare earth elements. *Photo by Robert Hill, CGS.*



Revised 6/2002

CALIFORNIA NON-FUEL MINERALS 2001

Total Value \$3.27 Billion

VALUES IN
MILLIONS OF
DOLLARS

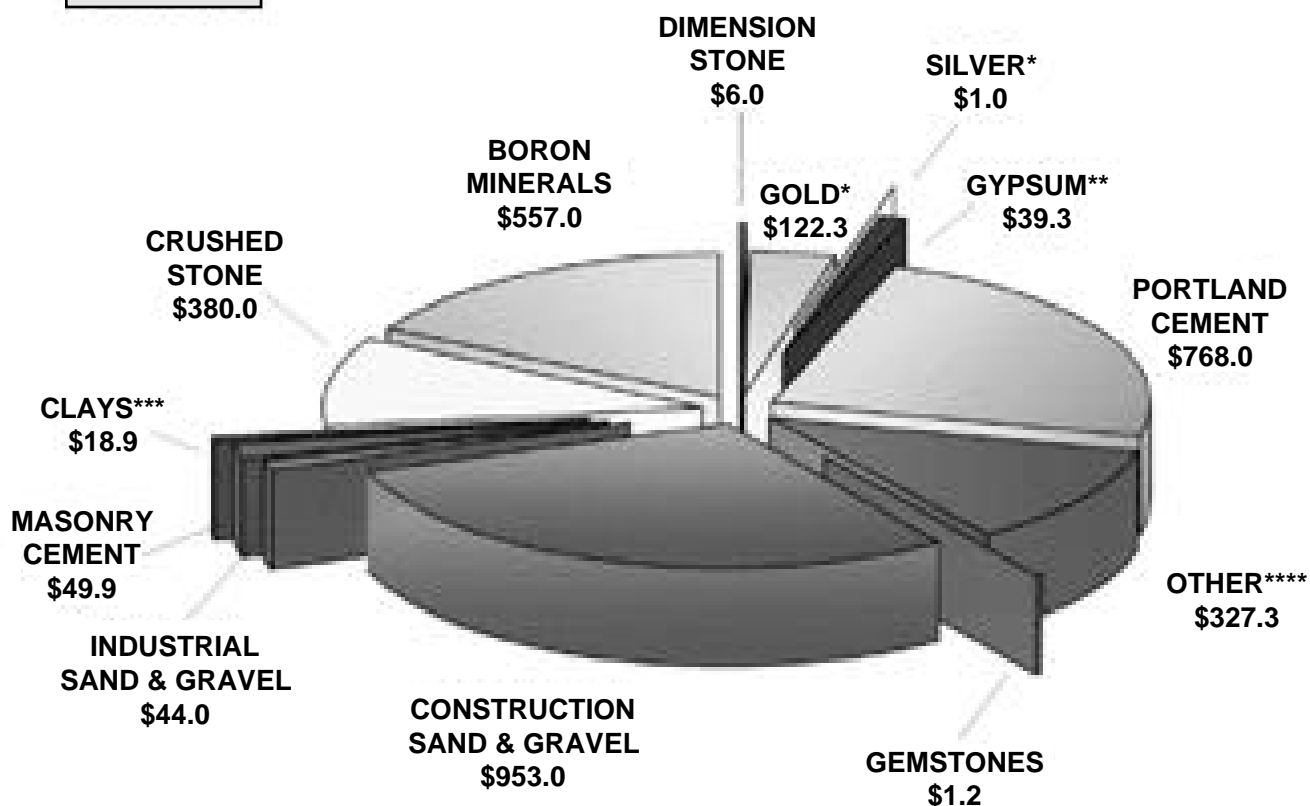

Data modified from U.S. Geological Survey
Mineral Information Service
(preliminary data)

*Data from California Geological Survey

**Includes calcined, byproduct and
crude gypsum

***Excludes fire, clay, kaolin,
and fuller's earth

****OTHER Includes:

Asbestos, diatomite, feldspar, fire clay, fuller's earth, iron ore, kaolin, lime, magnesium compounds, perlite, pumice and pumicite, pyrophyllite, rare earths, salt, soda ash, talc, sodium, bicarbonate, sodium sulfate and zeolites.



Amount and value of non-fuel mineral production for 1999, 2000, 2001. ^{1,2}

| Mineral | 1999 | | 2000 | | 2001 ³ | | |
|---|-------------|-------------------------|----------------------|-------------------------|----------------------|-------------------------|----------------------|
| | Quantity | Value (thousands \$) | Quantity | Value (thousands \$) | Quantity | Value (thousands \$) | |
| Asbestos | short tons | 7,900 | W | 5,800 | W | 5,800 | W |
| Boron Minerals (B ₂ O ₃) | short tons | 681,300 | 630,000 | 602,000 | 546,000 | 716,600 | 557,000 |
| Cement: | | | | | | | |
| Masonry | short tons | ⁴ 513,800 | ⁴ 38,300 | ⁴ 533,600 | ⁴ 43,200 | ⁴ 521,000 | ⁴ 49,900 |
| Portland | short tons | ⁴ 11,344,700 | ⁴ 816,900 | ⁴ 12,017,200 | ⁴ 821,000 | ⁴ 11,245,500 | ⁴ 768,000 |
| Clays | | | | | | | |
| Bentonite | short tons | 33,900 | 2,500 | 23,600 | 2,200 | 23,700 | 2,100 |
| Common | short tons | 1,017,900 | 9,400 | 1,067,800 | 16,800 | 1,068,300 | 16,800 |
| Gemstones | | NA | 1,100 | NA | 1,500 | NA | 1,200 |
| Gold ⁵ | troy ounces | 562,600 | 157,400 | 553,000 | 154,900 | ⁶ 449,200 | ⁶ 122,300 |
| Gypsum ⁷ | short tons | 3,561,800 | 18,700 | 3,534,600 | 45,600 | 3,197,200 | 39,300 |
| Sand and gravel: | | | | | | | |
| Construction | short tons | 159,505,300 | 897,300 | 163,170,000 | 940,000 | 163,170,000 | 953,000 |
| Industrial | short tons | 1,972,400 | 43,700 | 1,992,200 | 45,200 | 1,934,900 | 44,000 |
| Silver ⁵ | troy ounces | 257,200 | 1,300 | 281,700 | 1,400 | 233,800 | 1,000 |
| Stone: | | | | | | | |
| Crushed | short tons | 65,452,100 | 388,200 | 65,819,200 | 373,000 | 65,047,500 | 380,000 |
| Dimension | short tons | 32,400 | 4,900 | 35,700 | 5,800 | ⁸ 35,400 | ⁸ 6,000 |
| Combined value of diatomite, feldspar, fire clay, fuller's earth, iron ore (usable), kaolin, lime, magnesium compounds, perlite (crude), pumice and pumicite, rare earths, salt, soda ash, sodium bicarbonate, sodium sulfate, talk and pyrophyllite, zeolites, and values indicated symbol W | | XX | 341,500 | XX | 305,900 | XX | 327,300 |
| Total | | XX | 3,351,200 | XX | 3,302,400 | XX | 3,267,900 |

¹ Production as measured by mine shipments, sales, or marketable production (including consumption by producers).

² Quantity data are rounded to the nearest 100; values are rounded to the nearest \$100,000.

³ Recoverable content of ores, etc.

⁴ Data from California Department of Conservation, California Geological Survey.

⁵ Data modified from U.S. Geological Survey Mineral Information Service. Includes calcined, byproduct and crude gypsum.

⁶ Preliminary. ⁷ Estimate. NA=Not available. W=Withhold to avoid disclosing company proprietary data; value included with "combined value" data.

XX = Not applicable.

Modified from Mineral Industry Surveys: California, U.S. Geological Survey.



Syar Industries Inc.'s Lake Herman Quarry in Solano County. Jurassic basalt suitable for concrete-grade aggregate is mined here. The rock is a significant source of aggregate for the north San Francisco Bay region.
Photo by Don Dupras, CGS.

MINERAL RESOURCE CONSERVATION

The California Geological Survey's (CGS) Mineral Land Classification Project, a mandate of the Surface Mining and Reclamation Act, provides lead agencies with mineral resource maps. These maps have proven to be of great value in land-use planning and mineral resource conservation. In 2001, CGS completed a Mineral Land Classification report in Lassen County and continued projects in Solano, Napa, Sonoma, Marin, San Bernardino, and Riverside counties. CGS has classified mineral resources in more than one third of California.

Information provided by Susan Kohler, CGS.

*Visit the California State Mining
and Mineral Museum in Mariposa,
along historic Highway 49.
P.O. Box 1192
Mariposa, CA 95338
(209) 742-7625*

Offices of the California Geological Survey

Publications and Information Office

801 K Street, MS 14-33
Sacramento, CA 95814-3532
(916) 445-5716

Southern California Regional Office

655 South Hope Street, Suite 700
Los Angeles, CA 90017-3231
(213) 239-0878

Bay Area Regional Office

185 Berry Street, Suite 210
San Francisco, CA 94107-1728
(415) 904-7707

www.conservation.ca.gov

THE RESOURCES AGENCY
MARY NICHOLS
SECRETARY FOR RESOURCES

STATE OF CALIFORNIA
GRAY DAVIS
GOVERNOR

DEPARTMENT OF CONSERVATION
DARRYL YOUNG
DIRECTOR